



V1 AUTOMATIC

OWNER'S HANDBOOK

AND

SERVICE ITINERARY



FRAME AND ENGINE NUMBERS

The frame number is stamped on the right-hand side of the frame.
The engine number is stamped on the drive belt housing at the rear.



**IT IS ILLEGAL TO ALTER A FRAME NUMBER.
DOING SO MAY RENDER THE VEHICLE LIABLE TO CONFISCATION**

Vehicle details

Model: _____
Version: _____
Vehicle frame n°.: _____

Date first registered: _____
Owner: _____
Street: _____
City/postal code: _____
Phone: _____
Key ID n°.: _____
Colour: _____

Technical specifications

Cubic capacity: 460 c.c.
Power output: 29 kW (40 bhp)
Max. speed: approx. 75 mph (120 km/h)

N°. of seats: 2

Length: 3475 cm
Width: 1600-1640 cm
Height: 1200-1440 cm
Basic vehicle weight: 550 kg
Max. additional weight: 180 kg

Affix engine specification sheet here

Please present this handbook and service itinerary to your dealer whenever you bring the vehicle in for maintenance or servicing → **(summary of vehicle information for dealer)**
(TABLE OF CONTENTS ON PAGE 3)

TABLE OF CONTENTS

		Page
1.	General information and safety considerations	5 – 6
2.1	Controls, switchgear, warning lights and instruments	7 – 8
2.2	Parking lock	9
2.3	Checks before you ride your trike	10
2.4	Running in	10
2.5	Starting the engine	11
2.6	Automatic gearbox	12
2.7	Frame, front fork, rear dampers, rear axle	12 – 13
2.8	Bodywork	14 – 15
3.0	Braking system	16– 17
3.1	Fuel system, fuel	18
3.2	Type of fuel	18
3.3	Catalytic converter	19
3.4	Battery	20
3.5	Engine oil level	21– 22
3.6	Changing the oil filter	22
3.7	Differential gearbox	23
3.8	Removing the spark plugs	24
3.9	Removing the air filter	25
4.0	Checking the cooling system	26
4.1	Adjusting the headlamps	27
4.2	Rear-view mirrors	27
4.3	Top box and carrier	28
4.4	Tyres	29
4.5	Cleaning the vehicle	30
4.6	Putting the vehicle into storage	30
4.7	List of light bulbs	30
4.8	Fuses, relays	31
4.9	Troubleshooting	32
5.0	MagCode PowerSystemPro 12/24 V	33
5.1	Wiring diagrams - legend	34
5.2	Wiring diagram, relays and fuses	35
5.3	Wiring diagrams control unit	36
5.4	Wiring diagram, lights and instruments	37
6.0	Terms of warranty / general conditions and terms of business	38 – 40
7.0	Service booklet	41 – 46
8.0	Maintenance and service intervals	47 – 52
9.0	Pre-delivery vehicle checks	53

SYMBOLS USED IN THIS HANDBOOK



OBSERVE PERSONAL SAFETY

CAUTION

Failure to observe these rules fully and correctly can seriously endanger your **personal safety and health**.



PROTECT THE ENVIRONMENT

CAUTION

The following are hints and tips to prevent use of the vehicle having a negative effect on the **environment**.



OBSERVE TECHNICAL SAFETY

CAUTION

Failure to observe these rules fully and correctly can seriously endanger the technical safety of the vehicle and may cause the conditions of the warranty to become void.

The symbols shown here are very important. Wherever they have been included in this handbook, they underline the importance of the passages to which they refer. In such cases even greater attention must be paid to the instructions given. Each symbol is distinct from the other, making it clear and easy to understand the type of information to which they refer.

GENERAL INFORMATION AND SAFETY CONSIDERATIONS



WHEN RIDING, ALWAYS ENSURE THAT YOU ARE FULLY IN CONTROL OF YOUR TRIKE . NEVER RIDE UNDER THE INFLUENCE OF ALCOHOL, DRUGS OR EVEN MEDICATION. FAILURE TO OBSERVE THIS RULE PUTS THE SAFETY OF YOUR OWN PERSON AND OF OTHERS SERIOUSLY AT RISK.



ANY MODIFICATIONS TO THE VEHICLE'S PERFORMANCE, OR TO ITS STRUCTURAL FEATURES, ARE ILLEGAL. IN SUCH CASES THE VEHICLE NO LONGER CORRESPONDS TO ITS ORIGINAL AND APPROVED SPECIFICATIONS, AND IS TECHNICALLY UNSAFE TO RIDE.



NOTE

NEVER ADJUST THE REAR-VIEW MIRRORS WHILE THE VEHICLE IS MOVING, AS YOU RISK LOSING CONTROL OF THE TRIKE.



TO AVOID ACCIDENTS, ALWAYS DRIVE VERY CAREFULLY WHEN YOU HAVE FITTED ACCESSORIES AND WHEN THE VEHICLE IS CARRYING LUGGAGE. RIDING WITH ACCESSORIES AND WITH LUGGAGE MAY ADVERSELY AFFECT HANDLING CHARACTERISTICS, MAY REDUCE YOUR BOOM TRIKE'S PERFORMANCE, AND MAY LOWER THE LIMITS AT WHICH SAFE RIDING IS STILL POSSIBLE. WITHOUT ACCESSORIES, RIDING SPEEDS CAN BE HIGHER, BUT YOU SHOULD ALWAYS KEEP WITHIN THE LEGALLY PRESCRIBED LIMIT. IF ACCESSORIES FROM MANUFACTURERS OTHER THAN FROM BOOM TRIKES HAVE BEEN FITTED, IF THE VEHICLE IS CARRYING HEAVY LOADS, IF IT IS POORLY MAINTAINED, OR IF ROAD AND WEATHER CONDITIONS DICTATE, REDUCE YOUR RIDING SPEEDS EVEN FURTHER.

SAFE LOADS AND ACCESSORIES

If you equip your trike with accessories and ride it carrying luggage, then great care must be taken to avoid accidents. Fitting accessory parts and riding with luggage can severely affect a trike's handling stability, vehicle performance and safe handling characteristics, and may require you to significantly reduce riding speeds. Consider also that the above mentioned effects on safe handling may become even worse if you fit accessories made by other manufacturers, if the loads you are carrying are distributed unevenly, if the tyres are worn, if the trike is poorly maintained, if road or weather conditions are bad etc. Always consider the above before you equip your trike with accessories or carry extra luggage.

Make sure that the combined weight of rider, passenger, luggage and accessories **does not exceed 180 kg**.

ACCESSORIES

Original BOOM TRIKES accessories have been specially developed and tested to be compatible with your trike. BOOM TRIKES have not tested any accessories made by other manufacturers for the effects that they may have on the handling characteristics of your vehicle.

It is therefore your responsibility to find out about the safety risks and any accident risk involved if you equip your trike with accessories made by other manufacturers.

Always observe the following:

1. Check the accessory part thoroughly to make sure that it does not cover up any lights, impair ground clearance, obstruct handlebar turns, or the use of any of the controls.
2. Accessory parts which modify the riding position, increasing the distance between hands and feet and controls, may delay a rider's reaction in a potentially dangerous road situation.
3. Do not fit any electrical parts which overload the trike's electrical system. If a fuse blows, resulting in night-time failure of lights, or if the engine cuts out in heavy traffic, a potentially dangerous situation may arise.

Caution:

Any modifications to the trike or removal of original parts may lead to the vehicle being unsafe to ride and may also contravene existing laws. Always observe all legal requirements.



CAUTION: PLEASE READ CAREFULLY

A trike is a fascinating vehicle. It gives its rider a feeling of freedom, with power at his fingertips. However, you should always be aware of and accept the limits which trike riding dictates. You should carry out regular care and maintenance as a matter of course, ensuring that your trike is always in perfect condition.

Take care not only of your trike, but also of yourself. When riding, you will only remain in control of your vehicle if you are healthy and if you feel healthy. Substances such as alcohol, drugs of any kind, including those medically prescribed, should always be kept out of play, all the more so when you are riding a trike. As a trike rider you must always be in top form. Consuming even minor quantities of alcohol increases the likelihood that you will take risks.

Riders of trikes and motorcycles should always choose the best in protective gear: At the very least a full-face helmet, a full leather suit, leather boots and a good pair of gloves should be worn. But do not let your biking gear tempt you into a false sense of security. Always remember: a good trike rider exercises caution. Always observe this rule to make sure you keep out of harm's way even if others make mistakes.

A trike is likely to handle in a way which is different to other road vehicles, especially in rainy or bad weather conditions. Only an experienced car driver / motorcycle rider should take charge of a trike. We urgently recommend that you take part in a trike rider's safety course.



Note:

When you sell your trike, please be sure to pass this handbook on to the new owner

Before you take your trike out on the road always check:

- Oil and coolant levels
- Tyre pressures
- The amount of fuel in the tank

Before you take your trike out on the road always check the brake fluid level.

Also check the vehicle to ensure that it is in roadworthy condition, that the lights are in working order, and that all external parts are properly secured.

Polish chrome parts regularly using an appropriate cleaner, as otherwise the warranty on these parts of the vehicle will become void. All aluminium parts are highly susceptible to corrosion, and depending on the degree to which the vehicle is exposed to salt in the atmosphere, or to other corrosive influences, it will require more or less frequent cleaning.

As a result of continuous improvement to BOOM trikes, certain details of your trike may deviate from the specifications contained in this handbook.



SAFETY FIRST

The following is a brief guide to safe and carefree everyday riding. Your knowledge of the vehicle and your riding abilities are the key to ensuring that you travel the roads safely. Try the vehicle out on quiet roads with only occasional traffic until you are confident that you know how to ride the trike well.

1. Always wear a helmet.
2. When travelling on bad roads ride slowly and with caution.
3. Long journeys on wet roads without use of the brakes will cause braking performance to be weak at first. In such road conditions regularly operate the brakes to avoid this effect.
4. Do not carry out emergency stops on wet roads, or on loose or slippery surfaces.
5. Use of the vehicle on sand, muddy surfaces or on roads in wintery conditions: we recommend that you regularly clean the brake discs with a light cleaning agent, to avoid dirt collecting in the perforations which will otherwise accelerate brake pad wear.

2.1 CONTROLS, SWITCHGEAR, WARNING LIGHTS AND INSTRUMENTS

Handlebar controls: (Fig. 1)

Functions:

1. Headlight flasher (at front)
2. Light switch
3. Parking light
4. Dipped beam
5. Main beam
6. Horn
7. Indicator

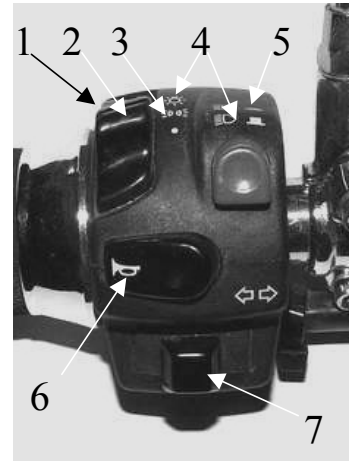

Fig. 1

Fuel tank instruments / standard specifications (Fig. 2):

1. Ignition switch
2. Water temperature gauge (standard specifications only)
3. Rear fog light switch
4. Hazard warning light switch
5. Brake fluid warning light



Fig. 2

Instruments

1. Speedometer
2. Tripometer
3. Fuel gauge
4. Flashing light
5. Oil pressure warning light
6. Main beam warning light
7. Alternator / engine fault warning light
8. Tachometer

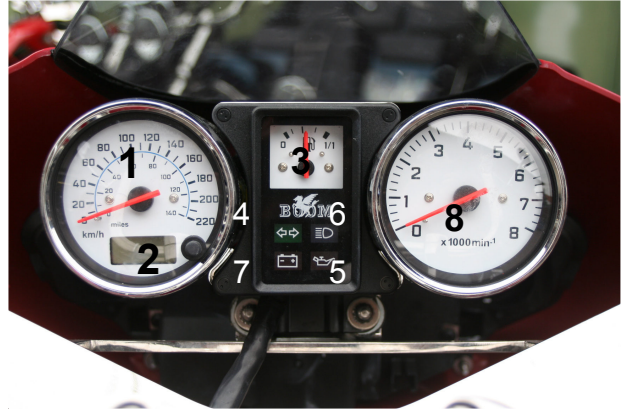

KNOW YOUR WARNING LIGHTS

A few seconds after you have started the engine the oil pressure warning light (red) should go off. If it stays on, stop the engine immediately and check the engine oil level. Running the vehicle with insufficient oil pressure can cause severe damage to the engine.



BRAKE FLUID WARNING LIGHT

If this light goes on, top up the brake fluid reservoir to the “Max” marking immediately. Take the vehicle to your nearest BOOM TRIKES dealer or any other specialist dealer to carry out a check on the braking system. Stop the vehicle immediately and have it towed!



ALTERNATOR / ENGINE FAULT WARNING LIGHT

A few seconds after you have started the engine this light must go off. If it does not go off, or if it lights up while you are riding the vehicle, stop the engine immediately and take the vehicle to your nearest BOOM TRIKES dealer .

2.2 PARKING LOCK

To activate the parking lock, turn the handlebars to the right. Insert the key, turning the barrel of the lock to the right, press and then lock. To unlock it, insert the key and proceed in reverse order. (Fig. 4).



PROTECTING YOUR TRIKE AGAINST THEFT

1. Always activate the parking lock and never leave the ignition key unattended in the switch. Obvious though these precautions are, they are equally easy to forget.
2. Make sure that your vehicle documents are complete and up to date. Carry them with you but never leave them unattended onboard the vehicle.
3. If possible, lock your vehicle in an enclosed garage space.
4. Write down your name, address and telephone number in this handbook.

2.3 CHECKS BEFORE YOU RIDE YOUR TRIKE



Caution: Failure to observe the section "Checks before you ride your trike" can lead to accidents or damage to the vehicle.

Check your trike regularly before you ride it. The checks listed below take very little time to complete and in the long run will save you time and help to protect both your wallet and your life.

1. Engine oil level: Check the oil level and if necessary top up.
Check the engine for oil leaks.
2. Fuel: Always refuel in good time.
Check the fuel lines for leaks.
3. Front/rear brakes: Check that the brakes are in good working order.
Ensure that there are no brake fluid leaks.
4. Tyres: Check the tyre pressures and the condition of the tyres.
5. Throttle: Ensure throttle action remains smooth when turning the handlebars from lock to lock.
6. Lighting equipment and horn: Check that headlamp, tail light, brake light, indicators, warning lights and horn are in proper working order.



Caution: Never let the engine run in an enclosed space. Exhaust fumes contain poisonous carbon monoxide which can lead to a loss of consciousness and ultimately cause death.

Never press the electric starter button for longer than 5 seconds at a time. Always wait for at least 10 seconds before attempting to start the engine again.



2.4 RUNNING IN

Run the vehicle in over the first 650 miles / 1000 km. Use only a moderate throttle during this period, and do not overrev. Vary engine speeds, avoid maintaining them constant.

Never use full throttle while running the engine in.

Only briefly warm up the engine at idling speed. Avoid travelling short distances, as otherwise the engine will not reach its correct running temperature.

2.5 STARTING THE ENGINE

This vehicle is equipped with an ignition cutout operated by the handbrake. If the handbrake is on, then the engine will not start.

This vehicle is equipped with a CVT automatic gearbox which engages directly with the rear wheels. When starting the engine, you must press the footbrake and the throttle must be shut. After the engine has started, release the footbrake and gently open the throttle.

The fuel injection system also comprises a vacuum pump and a choke which automatically assist engine starts.

EVEN SLIGHTLY OPENING THE THROTTLE WILL CAUSE THE AUTOMATIC GEARBOX TO TURN THE REAR WHEELS. AFTER STARTING, RELEASE THE FOOTBRAKE VERY SLOWLY AND GENTLY OPEN THE THROTTLE.

When you start the engine, the fuel injection system takes into account the engine temperature, ambient temperatures, and surrounding air pressure.

STOPPING THE ENGINE

Close the throttle and turn the ignition key to the OFF position. Remove the key.



PRECAUTIONS

TO AVOID DAMAGING THE ENGINE, NEVER RUN HIGH ENGINE SPEEDS AFTER A COLD START. WHEN TRAVELLING DOWNHILL TAKE CARE NOT TO EXCEED THE VEHICLE'S MAXIMUM SPEED. IF YOU EXCEED MAXIMUM ENGINE SPEED THEN A GOVERNOR WILL BE ACTIVATED TO PROTECT THE ENGINE FROM DAMAGE.



IF YOU HAVE RIDDEN A LONG DISTANCE AT MAXIMUM SPEED, NEVER STOP THE ENGINE IMMEDIATELY AFTERWARDS. LET THE ENGINE IDLE IN NEUTRAL FOR A FEW SECONDS FIRST.



CARRYING OUT ALTERATIONS MAY CAUSE SEVERE DAMAGE TO THE ENGINE. TUNING MEASURES OR ANY OTHER MODIFICATIONS TO EITHER THE ENGINE, THE CVT AUTOMATIC GEARBOX, OR TO THE VEHICLE ITSELF WILL INVALIDATE THE VEHICLE'S WARRANTY.

2.6 AUTOMATIC GEARBOX

The V1 is equipped with a CVT automatic gearbox.

To ensure the most comfortable ride possible the vehicle is equipped with an automatic gearbox, a centrifugal clutch and electronic engine management. This system was developed to obtain best possible acceleration and lowest possible fuel consumption both on even roads and up hills. If you stop the vehicle when travelling up a hill, e.g. at traffic lights or in a line of traffic, use only the brakes to keep the vehicle from rolling away. Do not open the throttle, instead let the engine idle.



If you use the engine to stop the vehicle from rolling backwards, due to excessive friction this can cause the clutch to overheat. The overheat is caused by clutch friction on the clutch body.

Avoid clutch friction over long periods. Other than in the situation described above, this can occur when on full throttle up steep hills, or when moving off on a steep hill with a passenger and luggage.

In the event of the clutch overheating observe the following precautions:

1. Do not ride the vehicle under these conditions over a long period.
2. If the clutch overheats, then let the engine idle in neutral for a few minutes to allow the clutch to cool down.

2.7 FRAME, FRONT FORK, REAR DAMPERS, REAR AXLE

A) Comfort fork (maintenance-free)

B) Telescopic fork

Front suspension is by a hydraulically operated telescopic fork. If the fork seals are no longer oiltight, then take the trike to a specialist dealer to carry out repairs. As the front fork is a safety-relevant part, if problems occur we urgently recommend that you contact your specialist. The front fork is a non-adjustable unit.

Each fork leg contains 270 c.c. of SAE 10W fork oil, which should be changed every 3 years.

B) Rear dampers



Fig. 5

The standard spring pre-load on the rear dampers offers an optimum compromise for riding either on your own or with a passenger, and in both these cases no further adjustment is required.

However, if most of the time the trike carries a passenger and large amounts of luggage, then adjust the pre-load to a higher setting (A).

ADJUSTING THE REAR DAMPERS

An adjuster wheel at the lower end of the unit allows continuous adjustment of the spring pre-load.



SPRING PRE-LOAD WHICH IS INCORRECT FOR THE RESPECTIVE WEIGHT OF THE VEHICLE CAN IMPAIR THE QUALITY OF THE RIDE AND MAKE IT UNSAFE TO USE THE TRIKE.



TO AVOID INJURY OR ACCIDENTS, WEAR PROTECTIVE GLOVES WHENEVER YOU ADJUST THE DAMPERS.



ALWAYS ADJUST BOTH DAMPERS TO EXACTLY THE SAME SETTING.

C) Rear axle

The rear axle is equipped with alloy swinging arms on either side. Snail cam adjusters A+B allow you to set toe-in and camber.

All V1 trikes are set up correctly at the factory and will normally need no further adjustment. The factory settings are:

Toe-in: - 0° 10' to - 0° 15'

Camber: 0°10'

If tyre wear is uneven, then please contact a specialist dealer who can check camber and toe-in and if required make the necessary adjustments.



Fig. 6

2.8 BODYWORK

The bodywork is made of ABS plastic. When cleaning please observe the following:



Fig. 7

Do not use petrol or spirits!

We recommend an anti-static spray cleaner for plastic surfaces.

Spray the surfaces and wipe them dry with a soft, lint-free rag. This will avoid a buildup of static and prevent dust particles from collecting on the surface. Normally available in 500 ml bottles.

This spray cleaner is available from your BOOM trikes dealer.

We also recommend that you use a soft rag to clean other plastic parts – not a microfibre rag – and that you do not use sponges or rags which have rough cleaning surfaces.



Fig. 8



Fig. 9

To lift up the body section, press the lever (Fig. 8) respectively on standard equipment trikes loose the body work connection.

After unlocking, press the body section up.
The liftomatic raises the body and holds
it in place.

To lower the body section, first press the body
up to release the locking mechanism of the liftomatic.



Fig. 10

Make sure that the handlebars are straight, i.e. the front wheel is pointing straight ahead, and that the handbrake is on. Otherwise you will be unable to lift up the body section fully, and will also risk damaging it.



Caution:

Whenever you ride the trike and whenever you tow the vehicle on an open trailer the body section must always be shut (using the liftomatic mechanism, or having secured it with bolts). When you close the body section make sure to lower it slowly, evenly and towards the centre of the vehicle, as otherwise you risk damaging the bodywork or the side covers.

3.0 BRAKING SYSTEM

A) BRAKE PEDAL



Fig. 11

To adjust the brake pedal, remove the cotter pin 1 and undo the nut 2 securing it (arrow). Now the pedal can be adjusted. Undo the nut on the footrest mounting and remove the screws. Now the footrest mounting can be adjusted.

Consider that sufficient ground clearance is given!

B) FRONT DISK

The front brake, operated by the integral braking system, is a legal requirement. Unlike a motorcycle, 80 % of braking loads are transmitted to the rear wheels, even at high speeds. Nevertheless, you should regularly check the front brake for wear, and the brake lines for any leakages.

Caution: The braking system should be maintained and repaired by specialist dealers only.

C) REAR BRAKE



Fig. 12

Wear to the brake pads and the discs is compensated by the system and has no effect on braking performance. Therefore as a rule no adjustment to the brakes will be required.

If resistance at the brake lever is spongy, then in all likelihood air has entered the brake lines. Since the brakes are of major importance to the overall safety of the trike, we urgently recommend that you contact a **specialist dealer** immediately to have him carry out the necessary checks.



CAUTION:

The vehicle must begin to slow down after the brake pedal has been depressed about one third of the way. Your specialist dealer will check for brake pad wear. If he fits new brake pads, and before you ride the vehicle, you should actuate the brake lever several times to ensure that the brake pistons return to their proper positions and so that brake lever travel readjusts itself.



D) HANDBRAKE

The full effect of the handbrake should be felt at the fourth click. If not, then access the linkage nuts depicted below to re-adjust. If this produces no results, then the brake pads will need to be replaced (Fig. 13).

If the handbrake is on, then the engine will not start. If the engine is running, then pulling the handbrake will stop the engine.



Fig. 13

E) CHECKING THE BRAKE FLUID LEVEL

The brake fluid reservoir for the front and rear brakes is situated beneath the plastic fuel tank. To check the brake fluid level you must first remove the tank.

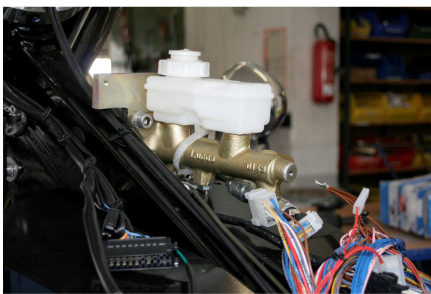

Fig. 14

The brake fluid level must always be between MIN and MAX markings.

If the brake fluid level has receded, then this can be due to brake pad wear. If the fluid is below the MIN marking, then you should contact a specialist dealer and have him carry out a thorough check of the braking system. If brake fluid is below the MIN marking, then the brake fluid warning light will go on.

TOPPING UP WITH BRAKE FLUID

Recommended brake fluid: **DOT 4 Lucas.**

Proceed as follows:

Remove the cover of the brake fluid reservoir. If necessary pull off the electrical connector. When topping up use only the brake fluid prescribed. Never exceed the upper marking (MAX).

USE ONLY DOT 4 BRAKE FLUID.



BRAKE FLUID IS A HAZARDOUS LIQUID. AVOID CONTACT WITH EYES, SKIN OR CLOTHING. IN THE EVENT OF CONTACT, IMMEDIATELY RINSE THE AFFECTED AREA THOROUGHLY WITH RUNNING WATER.



BRAKE FLUID IS HYGROSCOPIC, I.E. ABSORBS MOISTURE. IF BRAKE FLUID CONTAINS TOO MUCH MOISTURE, THEN BRAKING PERFORMANCE WILL DETERIORATE. NEVER USE BRAKE FLUID WHICH HAS BEEN STORED IN AN UNSEALED CONTAINER.

In a normal climate brake fluid should be changed every 12500 miles / 20,000 km, or at least every 2 years. Always contact a specialist dealer to let him carry out this task.

The brake fluid level, brake pad thickness, as well as the thickness of the discs should be checked at regular intervals.

! To ensure maximum braking performance from your brake discs, run them in over a distance of approximately 120 miles / 200 km.

During this period avoid making emergency stops.

After leaving a car wash, or in rainy and generally wet road conditions gently press the brake pedal to remove moisture from the disc !

3.1 FUEL SYSTEM, FUEL



Caution:

Petrol is highly inflammable, and under certain conditions can cause explosions. Always refuel in a well ventilated area, and make sure that the engine is off. Never smoke while refuelling or when in a fuel storage area; make sure that there are no naked flames nearby and that sparks cannot occur. Do not overfill the fuel tank. When you have finished refuelling, the pipe between the filler cap and the tank should be empty.

Make sure to close the filler cap properly. Do not spill any fuel. Petrol fumes and spilled petrol are easily ignited. In the event of spillage make sure that the area in question is dry before you restart the engine. Avoid repeated or prolonged contact with skin and do not inhale petrol fumes.

Keep out of reach of children!



Caution: Never let the engine's fuel pump run dry. This takes only a few seconds and damages the fuel pump beyond repair!



The filler pipe is located under the upper part of the passenger's backrest

Fig. 15

3.2 TYPE OF FUEL

Use only 95 octane petrol

Caution: Vehicles equipped with a catalytic converter may use unleaded petrol only. If by mistake you have filled up with leaded petrol (even a minor amount), then on no account start the engine, as this will damage the catalytic converter beyond repair.

BOOM TRIKES accept no responsibility for damage caused by the use of leaded petrol. Such damage shall be excluded from the conditions of warranty. If by mistake you have filled the tank with leaded fuel, then please contact an authorised BOOM TRIKES dealer, or a specialist dealer.

3.3 CATALYTIC CONVERTER

Never allow petrol to enter the catalytic converter, especially when the engine is hot:



- Never use up all the petrol in the fuel tank
- Avoid prolonged attempts at starting the engine
- Use battery jump leads
- Never turn off the ignition while the vehicle moving

Caution: If the ignition system malfunctions, or if performance is below normal, contact an authorised BOOM TRIKES dealer, or a specialist dealer. Do not use full throttle.



The catalytic converter is built into the exhaust silencer. Exhaust system temperatures can reach 1000 °C. Never park the vehicle in places where the surrounding vegetation can catch fire (woods, lawns etc.)



NEVER RIDE THE VEHICLE ON AN ALMOST EMPTY FUEL TANK. IF THE PETROL SUPPLY IS INTERRUPTED, DAMAGE MAY OCCUR TO THE CATALYTIC CONVERTER AND THE FUEL PUMP IS SURE TO BE DAMAGED BEYOND REPAIR.



USE OF A NON-RECOMMENDED FUEL NEGATIVELY AFFECTS THE PERFORMANCE OF THE EXHAUST AND FUEL SUPPLY SYSTEMS.



NEVER RUN THE VEHICLE UNTIL THE FUEL TANK IS COMPLETELY EMPTY. IF THIS OCCURS, DO NOT MAKE REPEATED ATTEMPTS AT STARTING THE ENGINE. TURN THE IGNITION TO THE "OFF" POSITION AND FILL UP WITH PETROL AS SOON AS POSSIBLE. FAILURE TO OBSERVE THESE INSTRUCTIONS CAN LEAD TO THE FUEL PUMP AND/OR CATALYTIC CONVERTER BEING DAMAGED BEYOND REPAIR.



YOU ARE STRONGLY ADVISED NOT TO USE FUEL FROM ANY OTHER SOURCES THAN NORMAL FILLING STATIONS. SUCH SUPPLIES MAY BE CONTAMINATED AND MAY DAMAGE THE FUEL SYSTEM'S PETROL FILTERS.



USE OF LUBRICANTS OTHER THAN THOSE WHICH HAVE BEEN RECOMMENDED CAN ACCELERATE WEAR IN THE ENGINE.

3.4 BATTERY (12V-18AH)

The battery is the part of the electrical system requiring closest attention and care. The most important rules for maintaining a battery are as follows:

Maintenance-free batteries

First-time use of a maintenance-free battery:

Caring for a maintenance-free battery is confined to checking the battery voltage and if necessary charging the battery. Checking the battery voltage must be carried out before the vehicle is delivered. A disconnected battery kept in storage must be charged every 6 months. Prior to delivery of the vehicle, in addition to the maintenance above, you must check the voltage and charge the battery every 6 months.

Charging a disconnected battery kept in storage:

1) Checking the battery voltage

Before connecting the battery to a vehicle use a normal voltage tester to check the voltage of the disconnected battery

- If the battery voltage exceeds 12.6 V, you may connect the battery to the vehicle.
- If the battery voltage falls below 12.6 V, then charge the battery as described under 2).

2) Charging a battery at a constant voltage rate

- Charge at a constant voltage rate between 14.4 and 14.7 V
- Initial charging current: a 0.3 to 0.5 x nominal voltage

Duration of charge:

Recommended: 10 – 12 hours

Minimum: 6 hours

Maximum: 24 hours

NEVER REVERSE THE CONNECTIONS TO THE BATTERY TERMINALS: THIS WILL CAUSE SHORT CIRCUITING AND RISKS DAMAGING THE ELECTRICAL SYSTEM.

NEVER DISCONNECT THE BATTERY TERMINALS WHEN THE ENGINE IS RUNNING, AS THIS CAN CAUSE IRREPARABLE DAMAGE TO THE ELECTRONIC IGNITION SYSTEM.

A SPENT BATTERY IS AN ENVIRONMENTAL HAZARD. RESPECT ENVIRONMENTAL LAWS AND DISPOSE OF IT IN AN APPROPRIATE CONTAINER.

If the vehicle is stationary for prolonged periods, then the battery will gradually discharge. This is due to natural discharging and due to consumers which are permanently supplied with electricity.

The rate at which the battery discharges also depends on ambient conditions and on whether the battery terminals are kept clean.

To avoid starting difficulties and severely damaging the battery, observe the following rules:

- **At least once a month:** start the engine and run it for 10 – 15 minutes at engine speeds slightly above idling speed. This keeps both the battery and the engine components in functional order.
- When you put the vehicle into storage (see instructions in the section „Putting the vehicle into storage“) remove the battery from the vehicle. Clean the battery, give it a full charge, and store it in a dry and well ventilated place. Charge the battery **at least once every two months.**
- It is recommended to use a current conservation unit which will be connected to the battery with an adapter cable. The battery needs not to be removed and is connected permanently to the charger while the vehicle is put into storage.

3.5 ENGINE OIL LEVEL

On 4-stroke engines, engine oil lubricates the drive components, main bearings and all of the engine's moving parts. **Running an engine with insufficient oil can cause severe engine damage.** On all 4-stroke engines, both oil consumption (to a certain degree) and gradual deterioration of oil properties are normal occurrences. The amount of oil an engine consumes is influenced heavily by the type of use the vehicle is put to, (for example prolonged periods of full throttle lead to increased oil consumption).

To avoid malfunctions, you should check the oil level at shorter intervals than those specified in the maintenance checklist, and prior to undertaking longer trips.

The vehicle is equipped with an oil pressure warning light (see 1.1)

1. Checking the engine oil level:



Fig. 16



Bild17

Check the oil level when the engine is cold.

- 1.) Place the vehicle on an even and level surface.
- 2.) Unscrew the dipstick (arrow), wipe with a clean cloth, replace the dipstick and screw in fully.
- 3.) Unscrew the dipstick again. Check the oil level. The oil level must be between the MIN and MAX markings (Fig. 18). If necessary top up with oil.

Oil at the MAX marking indicates that the engine contains approximately 1700 c.c. of oil. If you check the oil when the engine is hot, then the oil level reading will be lower. Allow a hot engine to cool down for approximately 10 minutes before checking the oil.

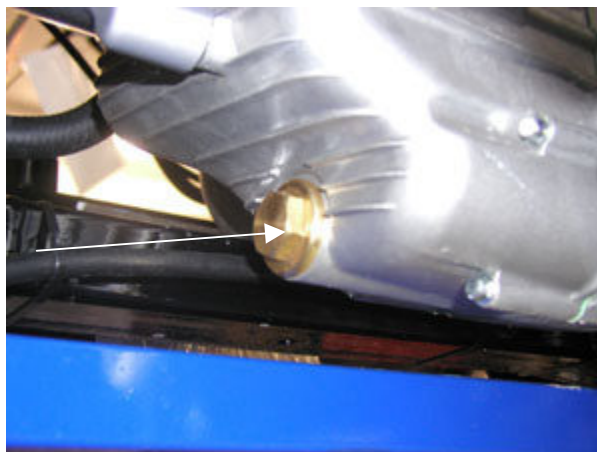
Fig. 18

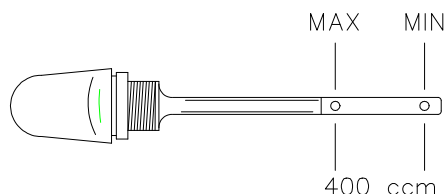

2. Topping up with oil:

Always top up **after** checking the oil level, as the MAX marking should never be exceeded.

Approximately 400 c.c. of oil are needed for topping up from the MIN to the MAX marking . As part of the service plan the maintenance checklist specifies checking the oil level, and topping up if required, at intervals of every 1860 miles / 3000 km.

3. Oil pressure warning light (insufficient oil pressure)



The vehicle has an oil pressure warning light which goes on when you turn the ignition key. After the engine has started this warning light must go off.

If the oil pressure warning light goes on during braking, in neutral, or when you ride the trike around bends, then you should check the oil level and if necessary top up. If after topping up the engine oil the warning light stays on when performing the same riding manoeuvres, then you should contact a specialist dealer.

4. Oil change

Every 6200 miles / 10000 km a specialist dealer should change the engine oil and the oil filter. Remove the sump plug on the drive side (Fig. 18) and drain all the oil from the engine. Unscrew the dipstick to speed up draining (Fig. 16). Unscrew the oil filter cartridge and discard. Before fitting a new oil filter cartridge lubricate the rubber seal. After an oil change a certain amount of oil always remains in the oilways, therefore you need only pour 2.3 ltrs. of new oil in at the filler cap.

Next, start the engine and run it for several minutes and then stop it again. Wait 5 minutes and check the oil level again, if necessary top up. **Do not exceed the MAX marking on the dipstick.** Always change the oil filter along with the oil. For oil changes and topping up we recommend synthetic oil SAE 5W/40.

3.6 CHANGING THE OIL FILTER

Caution:

Avoid contact with a hot engine as injury and burns may result

- Remove the oil filter.
- Remove the filler cap.
- Remove and clean the oil drain plug and clean.
- Use a strap wrench to remove the filter cartridge.
- Check the condition of the O-rings on the oil filter and on the oil drain plug.
- Lubricate the O-rings and screw the oil drain plug back in. Tighten to the correct torque.
- Before fitting a new oil filter cartridge lubricate the rubber seal. Hand-tighten the cartridge so that contact is made between the engine and the seal. Tighten to the correct torque.
- Pour in fresh oil as described above.

Torque settings:

Oil drain plug: 24 – 30 Nm

Oil filter: 12 – 16 Nm



INSUFFICIENT OIL OR USE OF THE WRONG OIL ACCELERATES WEAR OF MOVING PARTS AND CAN SEVERELY DAMAGE THE ENGINE.



RUNNING THE ENGINE WITH TOO MUCH OIL CAN LEAD TO MALFUNCTIONS OR MAY IMPAIR THE VEHICLE'S OVERALL PERFORMANCE.



USED OIL CONTAINS SUBSTANCES WHICH ARE HAZARDOUS TO THE ENVIRONMENT. A SPECIALIST DEALER SHOULD CARRY OUT THIS JOB, AS HE POSSESSES THE NECESSARY EQUIPMENT TO DISPOSE OF WASTE OIL IN COMPLIANCE WITH ENVIRONMENTAL LAWS.



USE OF LUBRICANTS AND/OR A SPARK PLUG OTHER THAN RECOMMENDED CAN CAUSE EXCESSIVE ENGINE WEAR.

3.7 DIFFERENTIAL GEARBOX

1. Gearbox oil level

To check the oil level in the differential gearbox (contains 1 litre), proceed as follows:

1. Place the vehicle on an even and level surface.
2. Unscrew inspection plug "A" (Fig. 21). If oil begins to run out then no topping up is required. If no oil runs out, then unscrew oil filler plug "B" (Fig. 19) and carefully top up with oil until it begins to run out of inspection plug "A". Screw both plugs back in and retighten.

Fig. 20 shows oil drain plug "C" for draining the differential gearbox.

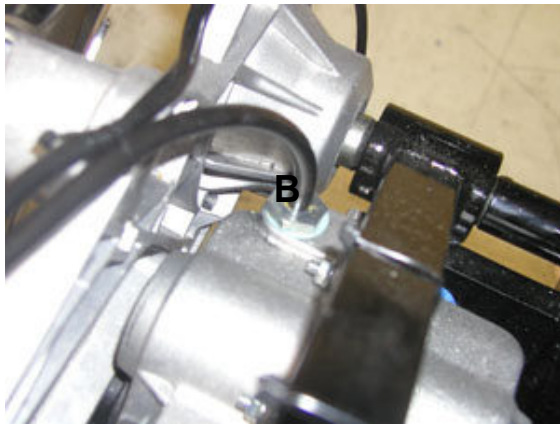

Fig. 19



Fig. 20

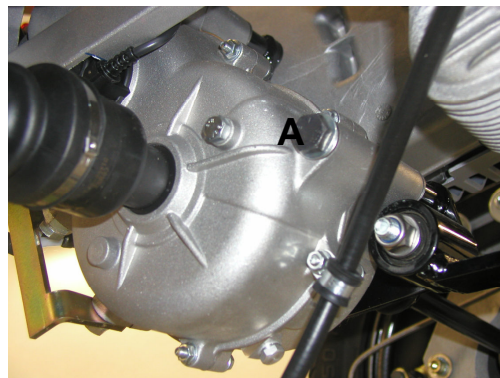

Fig. 21

Recommended oil grade: SAE 80/90



INSUFFICIENT OIL OR USE OF THE WRONG OIL IN THE DIFFERENTIAL GEARBOX ACCELERATES WEAR OF MOVING PARTS AND CAN SEVERELY DAMAGE THESE PARTS.

USED OIL CONTAINS SUBSTANCES WHICH ARE HAZARDOUS TO THE ENVIRONMENT. A SPECIALIST DEALER SHOULD CARRY OUT THIS JOB, AS HE POSSESSES THE NECESSARY EQUIPMENT TO DISPOSE OF WASTE OIL IN COMPLIANCE WITH ENVIRONMENTAL LAWS.

3.8 REMOVING THE SPARK PLUG

To remove the spark plug proceed as follows:

- 1.) Open up the body section and lift.
- 2.) Remove the spark plug cap (Fig. 22).
- 3.) Unscrew the spark plug.
- 4.) Screw the plug back in at the correct angle **by hand**.
- 5.) Only use the plug spanner to tighten the plug down.
- 6.) Replace the plug cap by pushing it down as far as it will go.

Recommended makes:
NGK CR7 EKB
CHAMPION RG6YC

Plug gap:
0.7 – 0.8 mm

Torque setting:
Spark plug - 10 Nm



Fig. 22

Caution:
Only remove and
replace the spark plug
when the engine is
cold!

Note:

USE OF A SPARK PLUG BY ANY OTHER MAKE THAN RECOMMENDED, OR OF UNSUPPRESSED SPARK PLUG CAPS CAN LEAD TO MALFUNCTIONS IN THE IGNITION SYSTEM .

ONLY REMOVE THE SPARK PLUG WHEN THE ENGINE IS COLD. CHECK THE SPARK PLUG EVERY 3700 MILES / 6000 KM, AND REPLACE IT EVERY 7500 MILES / 12000 KM. USE OF A DIFFERENT IGNITION SYSTEM OR OF A SPARK PLUG BY ANY OTHER MAKE THAN RECOMMENDED CAN SEVERELY DAMAGE THE ENGINE.

IF THE SPARK PLUG WAS REMOVED FOLLOWING ENGINE FLOODING (TO ALLOW PETROL TO EVAPORATE), THEN LEAVE THE PLUG CAP ATTACHED TO THE SPARK PLUG AND EARTH THE SPARK PLUG A GOOD DISTANCE FROM THE PLUG HOLE TO AVOID IGNITING THE MIXTURE COMING OUT OF THE CYLINDER HEAD.

3.9 REMOVING THE AIR FILTER

To remove the air filter proceed as follows:

- 1.) Undo the 9 screws holding the filter cover and remove them along with the cover.
- 2.) Remove the air filter and replace it with a new part. Replace the cover and the screws. Retighten.

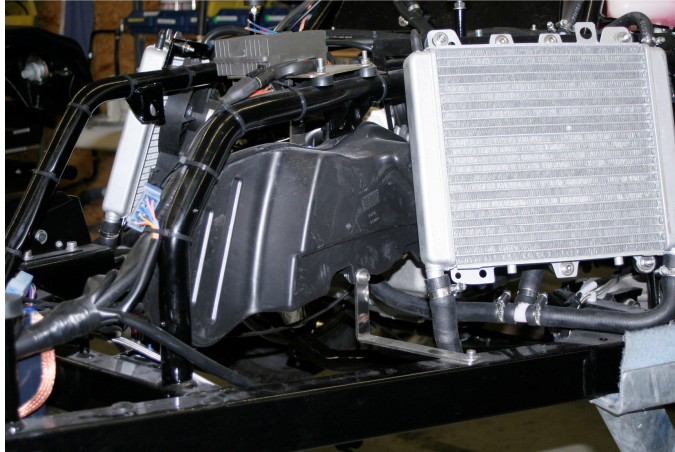

Fig. 23



Fig. 24

The maintenance checklist specifies that the air filter should be checked every 3800 miles / 6000 km by a specialist and if necessary cleaned with a high-pressure air hose. Clean from the side fitted closest to the engine (the inside) as the outer side is where road dust collects.

IF THE VEHICLE IS FREQUENTLY USED ON DUSTY ROADS, THEN TO AVOID DAMAGING THE ENGINE YOU SHOULD CHECK THE AIR FILTER AT SHORTER INTERVALS THAN RECOMMENDED IN THE MAINTENANCE CHECKLIST.

4.0 CHECKING THE COOLING SYSTEM

The engine cooling system runs on a mixture of water and coolant, maintained under high pressure. Total capacity is approximately 3.0 litres. The coolant used is **ready-mixed and consists of 50% distilled water and 50% coolant**, which is an ethylene glycol mixture and contains anti-corrosion additives. Recommended coolant: **PARAFLU 11 FE**. This is ready for use and requires no additional diluting. The coolant's optimum temperature range is between a minimum of 60°C and a maximum of 105°C, which will be shown on the water temperature gauge. If the red warning light goes on, then stop the engine immediately. Allow the engine to cool down and check the coolant level. If the level is correct then contact your specialist dealer.

PLEASE NOTE:

IF THE WARNING LIGHT GOES ON DURING NORMAL VEHICLE USE, THEN STOP THE ENGINE IMMEDIATELY AND ALLOW IT TO COOL DOWN. CHECK THE COOLANT LEVEL. IF THE LEVEL IS CORRECT THEN CONTACT YOUR SPECIALIST DEALER.

For checking the coolant the engine must be cold. Proceed as follows:

- a) Place the vehicle on an even and level surface.
- b) Turn the filler cap of the expansion tank anti-clockwise and remove.
- c) On the tank you will see MIN and MAX level markings (Fig. 27).
- d) Top up if the coolant is below MIN.

Make sure that the coolant level is always between MIN and MAX.

Fig. 25

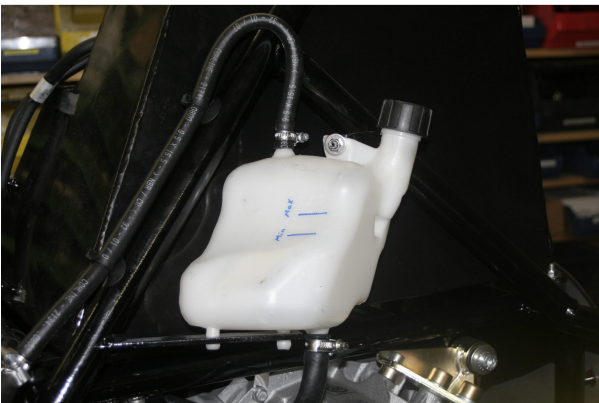

The expansion tank is situated beneath the plastic fuel tank.

TO AVOID DANGEROUS LOSS OF COOLANT WHILE THE VEHICLE IS IN USE, ALWAYS MAKE SURE THAT COOLANT DOES NOT EXCEED THE MAX MARKING.

If coolant is close to the MIN marking, then it must be topped up. Only top up with coolant when the engine is cold. If frequent topping up is necessary, or if the expansion tank is completely empty, then you must take the vehicle to a specialist dealer for him to check the cooling system and rectify the fault.

TO MAINTAIN CORRECT ENGINE PERFORMANCE ALWAYS ENSURE THAT THE RADIATOR GRILL IS KEPT CLEAN.

BEHIND THE RADIATOR NO ACCESSORIES OR LUGGAGE SHOULD BE PUT ON. OTHERWISE THE AIR FLOW IS HINDERED AND THE ENGINE OVERHEATS.

4.1 ADJUSTING THE HEADLAMPS

To adjust the headlamps proceed as follows:

1. Place the unladen and complete vehicle with correct tyre pressures on an even surface 10 metres away from a white wall slightly in the shade. The vehicle should point at right angles to the wall.
2. Draw a horizontal line on the wall, approximately 2 ft. 3 ins. / 67 – 70 cm high.
3. Switch on dipped beam and adjust the headlamp angle so that light meets the wall below this line.



Fig. 26



Fig. 27



Fig. 28

We recommend that you take the vehicle to an authorised specialist to adjust the headlamps

4.2 REAR-VIEW MIRRORS

To adjust a rear-view mirror, gently press a mirror edge and turn it in the direction required.

4.3 TOP BOX AND CARRIER

Releasing and removing the top box from its carrier.



Fig. 29

To access the top box compartment insert the red key inside the lock and turn it to the right through 90°.

To open the top box, press button “B” to release the flap.
Now the top box can be opened. To close the top box proceed in reverse.

To release the top box unlocking it with the key and by pressing “A”. Pull out handle “C” and remove the top box.

For cleaning and general care follow the manufacturer’s recommendations.

A MAXIMUM WEIGHT OF 15 KG MAY NOT BE EXCEEDED!

4.4 TYRES

Regularly check the tyre pressures.



FITTING TYRES OTHER THAN THOSE RECOMMENDED CAN LEAD TO UNSTABLE HANDLING. WE URGENTLY RECOMMEND THAT YOU ALWAYS FIT TYRES WHICH CONFORM TO THE ORIGINAL VEHICLE SPECIFICATIONS.

The tyres have tread markers to indicate the degree of wear. Replace the tyres as soon as these markers become visible on the tread. Check the tyres for damage, e.g. cuts or an uneven pattern of wear. To replace tyres, contact a specialist dealer or a tyre dealer with the necessary workshop equipment.

FRONT WHEEL: 2.3 bar – REAR WHEELS: 2.5 bar

PUNCTURES

This vehicle is equipped with tubeless tyres. If a puncture occurs then air takes much longer to escape than from a tube. On the roads this ensures a greater safety margin. Temporary repairs can be effected by using a tyre repair foam, or a tyre repair kit for tubeless tyres.



REFER TO THE MANUFACTURER'S INSTRUCTIONS ON HOW TO USE TYRE REPAIR FOAM.

In order for permanent tyre repairs to be carried out, or in order to change a tyre we recommend that you contact a specialist dealer. In order to change a tyre the corresponding wheel will have to be removed. Contact your specialist dealer to have him carry out this job.



FRONT AND REAR WHEELS MUST ALWAYS BE BALANCED. RIDING A VEHICLE WITH UNBALANCED WHEELS OR WITH INCORRECT TYRE PRESSURES CAN LEAD TO ACCIDENTS.

4.5 CLEANING THE VEHICLE

Use water from a low-pressure hose to loosen road dirt and deposits on painted surfaces. When water has loosened the deposits, use a soft sponge along with ample water and a car shampoo (2-4% of shampoo to in the water). Rinse off thoroughly with clear water and wipe down with a chamois leather rag. Clean the outside of the engine with paraffin, a brush and a clean rag. Paraffin causes damage to paintwork. Finally, apply a silicone wax finish, but only after you have finished washing the bodywork.

CLEANING AGENTS CONTAMINATE WATER RESOURCES. YOU SHOULD ONLY CLEAN THE VEHICLE IN PLACES WHICH HAVE SYSTEMS FOR RECYCLING WASTE WATER.

IF YOU USE A HIGH-PRESSURE WATER HOSE TO CLEAN THE ENGINE, THEN PLEASE OBSERVE THE FOLLOWING:

- Adjust the nozzle to a spray, do not use a narrow water jet.
- Hold the hose at least 2 feet / 60 cm away.
- Water should be no warmer than 40° C.
- Do not use a high-pressure water jet.
- Do not use a steam cleaner.
- Never aim the hose directly at the following parts: fuel injection system, electrical wiring, air intakes on the gearbox and flywheel covers, any electrical components, instruments, steering head.

Never wash the vehicle in direct sunlight, particularly in summer, when the bodywork has warmed up and shampoo bakes onto the surface before you can wipe it off. This can damage the paintwork. Never use rags with petrol or paraffin to clean the paintwork, as this affects the gloss and damages the surface's properties. Depending on the vehicle colour (satin colours), applying silicone wax may damage the paintwork. For more information ask your specialist dealer.

4.6 PUTTING THE VEHICLE INTO STORAGE

Before putting the vehicle into storage we recommend that you carry out the following:

1. Clean all parts of the vehicle and fully enclose it with a protective cover.
2. With the engine switched off and the piston at bottom dead centre, remove the spark plug and inject approximately 1 – 2 c.c. SELENIA HI Scooter 4Tech oil. Press the starter once or twice and screw the spark plug back in.
3. Fill up the fuel tank.
4. Observe the battery maintenance recommendations in section 3.6.

4.7 LIST OF LIGHT BULBS

Function	Type	Volts / Watts
Dipped beam	Halogen H4 / HB3 on jetlights	2 x 12V-55W
Main beam	Halogen H4 / HB3 on jetlights	2 x 12V-60W
Front parking light	All glass	2 x 12V-5W
Indicators, front	Bulb	2 x 12V-21W
Tail light	LED circuit module	2 x 12V
Brake light	Bulb	2 x 12V-21W
Indicators, rear	Bulb	2 x 12V-21W
Instrument lights	All glass	5 x 12V-2W
Number plate light	Festoon	1 x 12 V-5W
Rear fog light	Bulb	1 x 12V-21W
Reverse light	Bulb	1 x 12V-21W
Headlight	Without function	

4.8 FUSES, RELAYS

ALWAYS FIND AND RECTIFY THE FAULT THAT LED TO A FUSE BLOWING BEFORE YOU REPLACE IT: NEVER USE ALTERNATIVE METHODS OF BRIDGING THE ELECTRICAL CIRCUIT (E.G. WIRE).

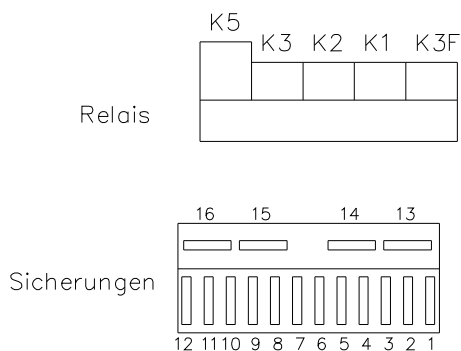
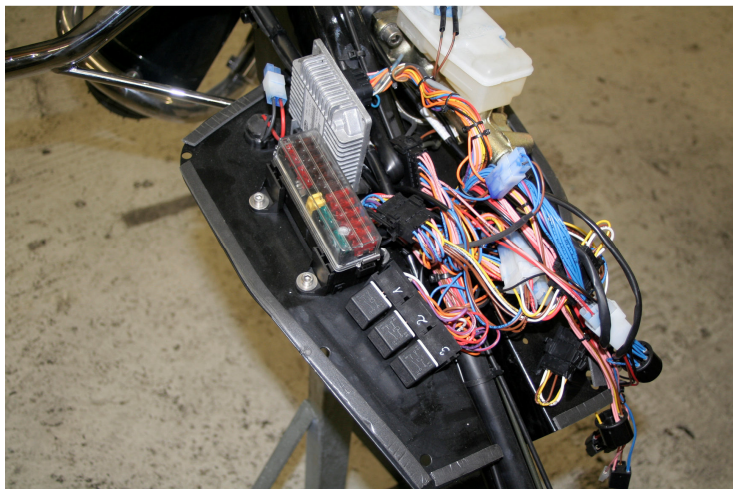

Fig. 30

Fuses and relays are located beneath the fuel tank.

Relays:

- K1 = Power supply
- K2 = Starter relay
- K3 = Fan relay
- K3F = Additional relay, headlamp fairing
- K5 = Indicator relay

See page 34 - 37

Fuses:

- F1 = Parking light, left – 7.5 A
- F2 = Parking light, right – 7.5 A
- F3 = Dipped beam, left 7.5 A
- F4 = Dipped beam, right 7.5 A
- F5 = Main beam, left – 7.5 A
- F6 = Main beam, right – 7.5 A
- F7 = Horn, engine cutout relay –10 A
- F8 = Brake/ tail light –10 A
- F9 = Instruments –10 A
- F10 = Hazard warning lights –10 A
- F11 = Engine management –10 A
- F12 = Engine management and power supply –10 A
- F13 = Additional fuse for battery –10 A
- F14 = Power supply to alternator –10 A
- F15 = Jet lights, right – 30 A
- F16 = Jet lights, left – 30 A

4.9 TROUBLESHOOTING

SYMPTOM	POSSIBLE CAUSE	SOLUTION
ENGINE WILL NOT START	Handbrake on Fuse blown	Release handbrake Replace fuse and contact specialist dealer
STARTING DIFFICULTIES	Fuel tank empty	Fill up with petrol
	Fuel injection system malfunction	Contact specialist dealer
	Damaged petrol pump	Contact specialist dealer
	Flat battery	Charge battery
LOW COMPRESSION	Defective spark plug	Replace spark plug
	Defective electronic management/ fuel injection system	Always contact specialist dealer, as safety risks are involved when working on high voltage
	Loose spark plug	Tighten spark plug
	Cylinder head not tightened down properly, worn piston rings, sticking valves	Contact specialist dealer
HIGH PETROL CONSUMPTION AND LOW ENGINE PERFORMANCE	Air filter clogged	Clean with air hose, alternatively replace.
INADEQUATE BRAKING PERFORMANCE	Oil or grease on brake discs. Worn brake pads, braking system malfunctioning.	Contact specialist dealer
POOR SPRINGING / DAMPING	Defective or leaking dampers, worn stop rubbers, incorrect spring pre-load	Contact specialist dealer
PROBLEMS WITH AUTOMATIC GEARBOX	Worn pulleys or drive belt	Contact specialist dealer

IMPORTANT:

NEVER RUN THE VEHICLE UNTIL THE FUEL TANK IS COMPLETELY EMPTY. HOWEVER, IF THIS OCCURS, DO NOT MAKE REPEATED ATTEMPTS AT STARTING THE ENGINE. TURN THE IGNITION TO "OFF" AND FILL UP WITH PETROL AS SOON AS POSSIBLE. FAILURE TO OBSERVE THESE INSTRUCTIONS CAN LEAD TO THE FUEL PUMP AND/OR CATALYTIC CONVERTER BEING DAMAGED BEYOND REPAIR.

5.0 MAGCODE POWERSYSTEMPRO 12/24V

Important information for the outdoor use of the Power System 12/24 V (Hints by Company MagCode):

To extend the operational life span of this product, the following measures should be taken:

- after the outdoor use of the Port clean it quickly with a cloth
- from time to time remove cutting debris on the side of the contact of Port and Clip with an adhesive strip.
- Every 1 – 2 months spray some contact spray on Port- and Clip contacts.

Attention:

The MagCode PowerSystemPro 12/24V is outfitted with a mechanic bayonet cap. It can be cut without unlocking under load, what can cause damages and/or a malfunction of the system. Thus always unlock manual!

NEW:

As of now available – retrofittable problem-free:

Covering for Code PowerPort 12V/24V and MagCode PowerPortPro 12V/24V.

More detailed product information (e. g. installation manual) on our website (www.magcode.com).

MagCodePowerClip



1. Cut-off existing plug - notice polarity.



2. Open **MagCodePowerClip** and remove pull relief.

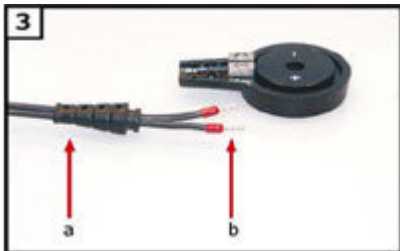

3. Cut grommet to size for thicker cables (3a) and apply multicore wiring sleeves (3b).

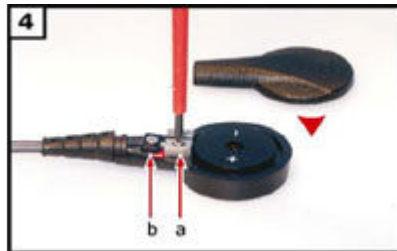

4. Fix cable ends in screw terminals (4a)(notice polarity) and mount pull relief (4b) and grommet.



5. Close housing with screw - Ready!

5.1 WIRING DIAGRAMS – LEGEND

Power supply	
S1	Ignition switch
X6	Alternator
B+	Battery
F1	Fuse, parking light, left
F2	Fuse, parking light, right
F3	Fuse, dipped beam, left
F4	Fuse, dipped beam, right
F5	Fuse, main beam, left
F6	Fuse, main beam, right
F7	Fuse, horn, engine cutout relay
F8	Fuse, brake light, tail light
F9	Fuse, instruments
F10	Fuse, hazard warning lights
F11	Fuse, engine management
F12	Fuse, engine management and power supply
F13	Additional fuse battery
F14	Back up light / Accessories (X38) = 10A
F15	Additional fuse 30A
F16	Additional fuse 30A

Lights / brake lights	
X4	Switch handlebars
S3	Switch fog light
BS	Switch brake light
E1	Dipped beam, left
E2	Dipped beam, right
E3	Main beam, left
E4	Main beam, right
E5	L/h parking light inside headlamp
E6	R/h parking light inside headlamp
E7	Tail lamp, left
E8	Tail lamp, right
E9	Parking light, right, on wing
E10	Parking light, left, on wing
E11	Rear fog light
E12	Reverse light
E15	Instrument lights
E16	Number plate light
H7	Brake light, left
H8	Brake light, right
H9	Additional brake light
H12	Main beam warning light
RS1	Tail light switch 1
RS2	Tail light switch 2
TK2	Touch sensitive switch throttle valve
SV	Tail light switch 3

Indicators / Hazard warning lights / Horn	
S5	Hazard warning lights
K1	Indicator relay
H5	Indicator left at headlamp
H2	Indicator right at headlamp
H3	Indicator left rear
H4	Indicator right front
H10	Indicator warning light
H10/2	Indicator buzzer
H11	Indicator control lamp, trailer
H18	Horn
H18/2	Horn water temperature
K7	Relay Horn water temperature

Warning lights / additional instruments	
B4	Sensor handbrake warning light
B5	Sensor brake fluid level
WT	Water temperature gauge – additional instrument
H20	Brake fluid control light
H21	Alternator control light
H22	Oil pressure control light
U1	Reservoir gauge
U2	Water temperature gauge
U5	Tacho

Engine	
DKP	Throttle valva – potenitometer
OS	Oil pressure switch
LTS	Engine speed / air temperature sensor
OTS	TDC sensor
MTS	Engine temperature sensor
ZS	Ignition coil
M1	Electric starter
KSPG	Fuel pump
KLS	Radiator
LLS	Connector neutral indicator
K1	Power supply relay, engine management
K4	Starter relay
K3	Fan relay
K2	Engine cutout relay
K6	Relay start lock-out
S11	Coolatnt temperature switch
DIAG	Connector engine diagnostics
ESV	Injeciton valve
SG	Engine management

Connectors	
X3	22-pin, to cockpit
X4	10-pin, to handlebars switchgear
X5	8-pin, to trailer coupling
X14	6-pin, to front lights, l/h
X15	6-pin, to rear lights, l/h
X16	6-pin, to front lights, r/h
X17	6-pin, to rear lights, r/h
X18	3-pin, to number plate / tail light
X21	3-pin, to tacho sensor
MP1	Earth connection to frame
B-	Earth connection to battery

5.2 WIRING DIAGRAM – RELAYS AND FUSES

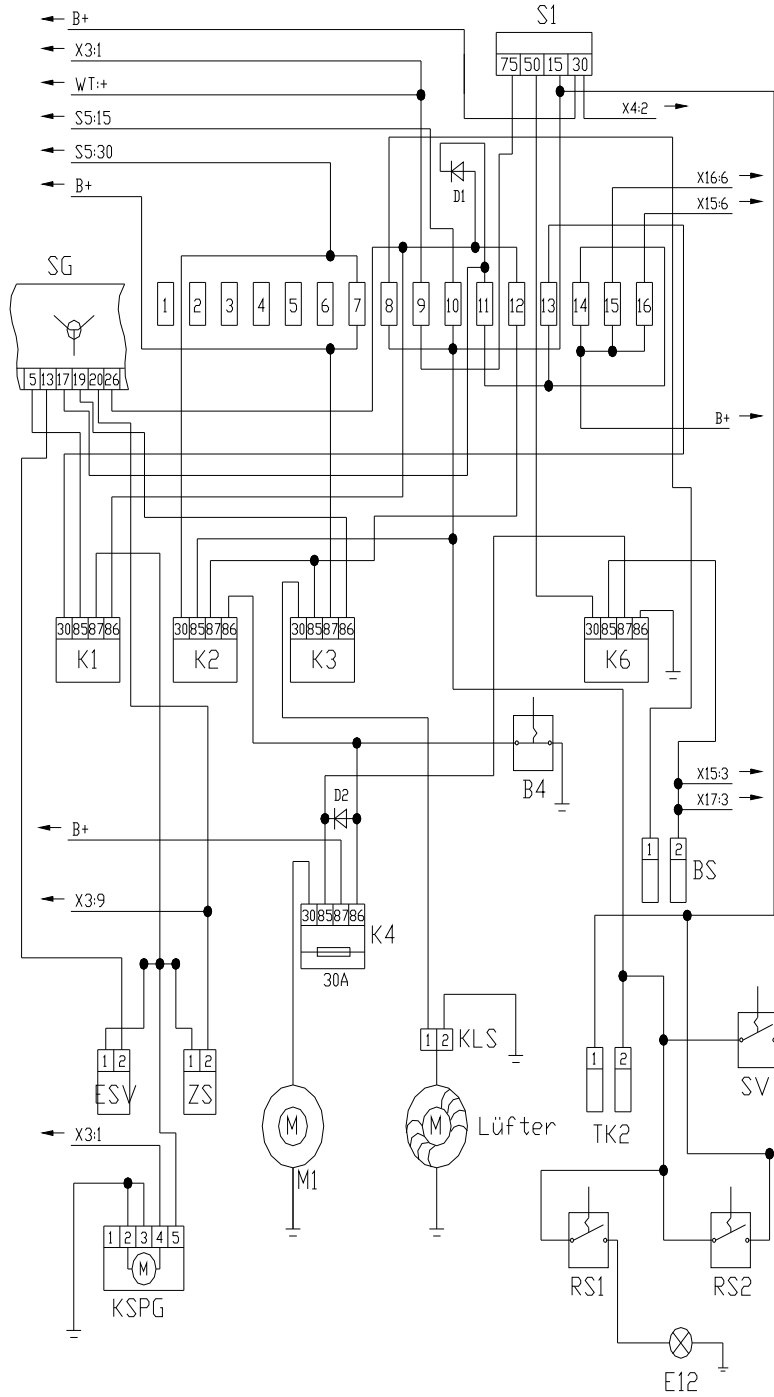

5.3 WIRING DIAGRAM – ENGINE MANAGEMENT

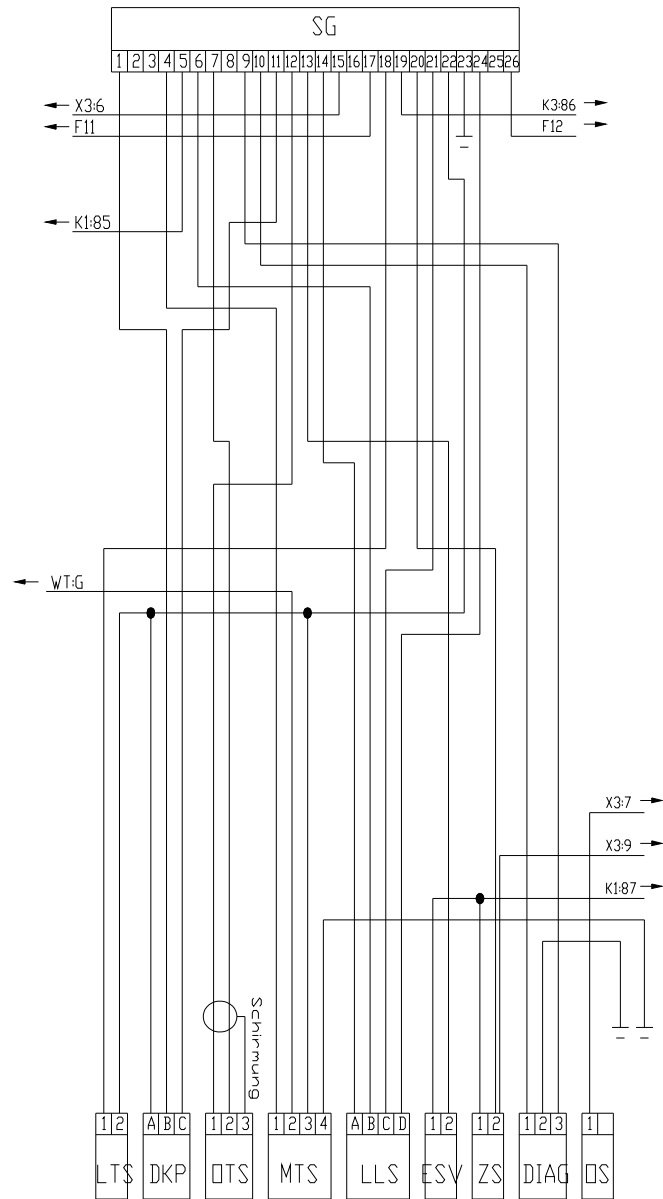

5.4 WIRING DIAGRAM - LIGHTING AND INSTRUMENT

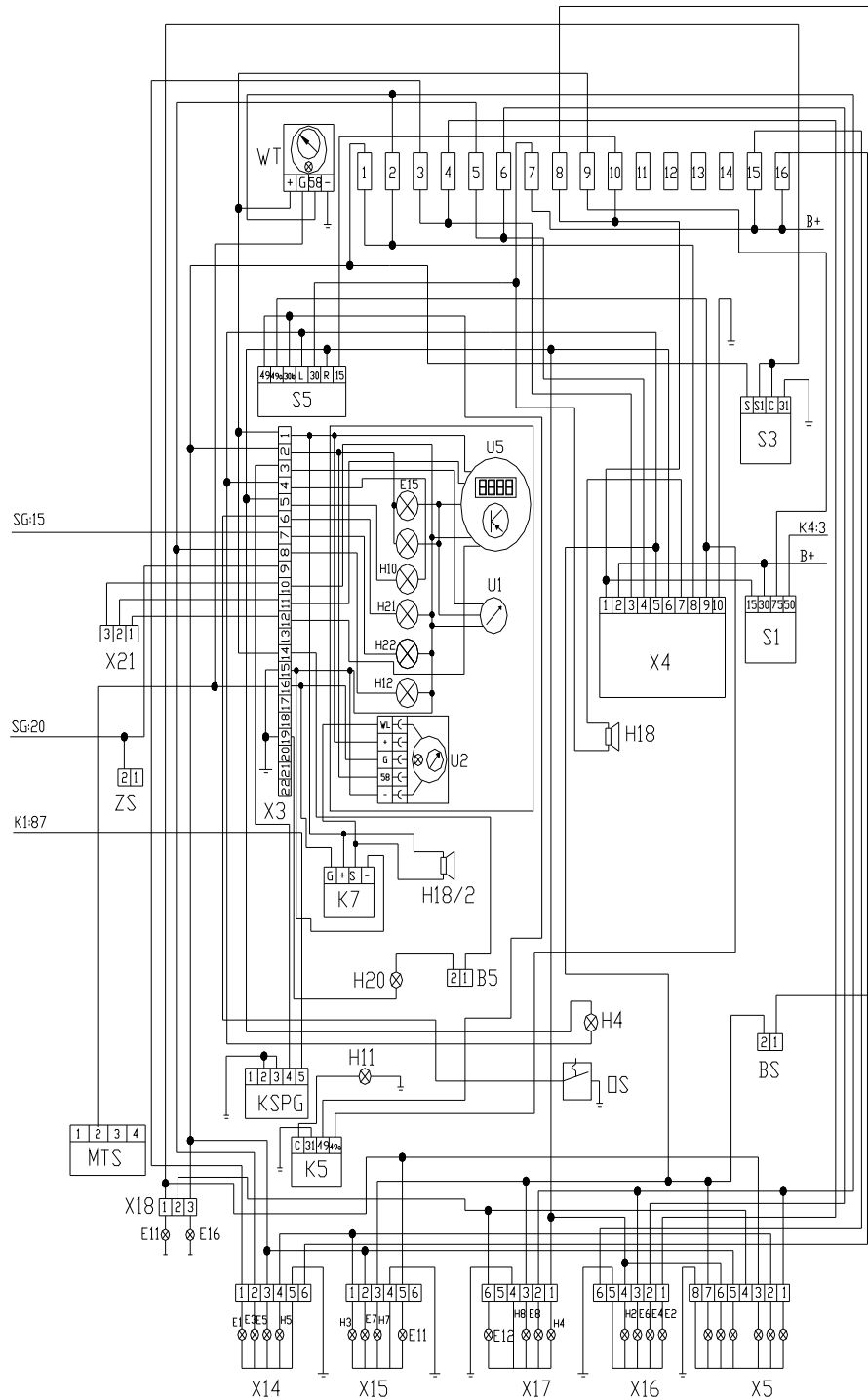

6.0 TERMS OF WARRANTY / GENERAL CONDITIONS AND TERMS OF BUSINESS

I: Conditions – scope of application

Deliveries, services/performances and offers made by us shall be governed solely by the following general terms and conditions of business. These shall also be valid for all future business dealings, even if no express reference is made to them. These conditions shall be considered as accepted, at the latest, at the time of acceptance of the service rendered. Any reference by customers or suppliers to their own general terms and conditions and conditions of purchase which are contrary to the terms and conditions mentioned above, are hereby rejected.

II: Conclusion of a purchase agreement / transfer of the buyer's rights and obligations; resale of the object prior to receipt

1. The buyer is bound by the purchase order for a maximum of 4 weeks. A purchase agreement shall be considered concluded if, within the period stated above, the vendor confirms, in writing, that he has accepted a purchase order for a specific object, or if delivery has taken place. If the vendor does not accept the purchase order, however, he is obliged to inform the buyer without delay.

2. Any transfer of the buyer's rights and obligations arising from the purchase agreement, and any resale of the object prior to its receipt shall require the written permission of the vendor. In the case of a breach or attempted breach of this provision the vendor may withdraw from the purchase agreement, in writing and without notice.

III: Prices

1. The price of the object of purchase is the manufacturer's price, plus delivery fees and VAT, the sum total being the purchase price. Additional services / performances will be charged separately.

2. Following conclusion of the purchase agreement, the buyer is obliged to make a payment equal to 20 % of the goods' sale value. If the vendor does not receive the payment as agreed, then after issuing a reminder to pay the agreed sum within a reasonable period of time, he shall be entitled to withdraw from the purchase agreement or to claim indemnity from the buyer due to non-fulfilment of obligations.

IV: Payment

1. The purchase price and prices for additional services/performances shall be paid in full upon delivery of the object of purchase and upon delivery of the invoice or other billing documents personally or by any other means.

2. The buyer may offset the demands of the vendor only if the buyer's counterclaim is undisputed or on the basis of an existing legally enforceable claim. A right of retention may only be asserted on the basis of claims arising from the purchase agreement.

V: Delivery and delayed delivery

1. Delivery dates or delivery deadlines, which may be binding or non-binding subject to agreement, shall be confirmed in writing. Delivery deadlines apply from the date on which the purchase agreement is concluded.

2. If six weeks elapse after an agreed non-binding delivery date or non-binding delivery deadline without delivery of the ordered object, then the buyer is entitled to demand that the vendor delivers the object of purchase. The vendor shall be in default as from receipt of this demand. If the buyer is entitled to claim indemnity for damages arising from default, this will be restricted to a maximum of 5 % of the agreed purchase price in the case of ordinary negligence on the part of the vendor. If the buyer also decides to withdraw from the purchase agreement and/or claim indemnity in lieu of fulfilment, following expiry of the six-week deadline and in accordance with sentence 1, he is obliged to set the vendor a reasonable delivery deadline. If the buyer is entitled to claim indemnity in lieu of fulfilment, this shall be restricted to a maximum of 25 % of the agreed purchase price in the case of ordinary negligence on the part of the vendor; if the buyer is a legal entity in the public sector, or represents a public sector special fund, or is a business person who was acting in a commercial capacity or in his capacity as a self-employed person when he concluded the agreement, there shall be no entitlement to indemnity in the case of ordinary negligence. In the event of the vendor being unable to deliver the object of purchase through no fault of his own whilst still in default, he will be obliged to offer indemnity in accordance with the limitation stated above. The vendor shall not be liable to offer indemnity if the damages would have also occurred even if that fulfilment had taken place on time.

3. If a binding delivery date or a binding delivery deadline elapses without the purchase object being delivered, the vendor shall automatically be in default. The rights of the buyer shall then apply in accordance with Item 2, sentences 3 to 6 of this Section.

4. Acts of God, or disturbances affecting the business operations of the vendor or his supplier, which temporarily prevent the vendor through no fault of his own from delivering the object of purchase on the agreed date or by the agreed delivery deadline, have the effect of suspending the dates and deadlines stated in items 1 to 3 for the duration of the disturbance caused by such circumstances. If the disturbance causes fulfilment to be suspended for more than four months, the buyer shall be entitled to withdraw from the purchase agreement. All other rights in respect of withdrawal from the agreement shall remain unaffected.

5. The manufacturer shall reserve the right to alter the vehicle specifications, make modifications to the shape and colour, and to change the scope of the delivery, providing that, taking into account the interests of the vendor, the buyer can be reasonably expected to tolerate the aforesaid changes or modifications.

6. If the customer is a business person, then, unless he has previously obtained a written statement of our consent, he shall not be permitted to resell to countries outside the EU, either direct or indirectly, the goods which we have delivered.

7. All risks shall be transferred to the customer as soon as the goods are in the charge of the person responsible for their transport, or as soon as the goods have left the vendor's storage facilities for subsequent carriage and delivery.

VI: Acceptance of the object of purchase

1. The buyer is obliged to accept delivery of the object of purchase within 8 days following notification of delivery. In the event that the buyer does not accept delivery of the object of purchase the vendor is entitled to assert his legal rights in this connection.
2. If the vendor claims indemnity, this shall be equal to 15 % of the agreed purchase price. The final amount may vary, subject to the vendor proving damages to be greater, or the buyer proving damages to be less.

VII: Reservation of ownership

1. The object of purchase shall remain the property of the vendor until all rightful demands of the vendor arising from the purchase agreement are fulfilled. If the buyer is a legal entity in the public sector, or represents a public sector special fund, or is a business person who was acting in a commercial capacity or in his capacity as a self-employed person when he concluded the agreement, the same reservation of ownership also applies in respect of the vendor's demands towards the buyer in the ongoing business relationship, until such time as the vendor's rightful demands in connection with the said purchase have been fulfilled. If the buyer so requests, the vendor is obliged to renounce his reservation of ownership on condition that the buyer has indisputably fulfilled all the demands existing in connection with object of purchase, and on condition that adequate collateral exists as cover for other demands arising from an ongoing business relationship. For the time period in which he still has reservation of ownership, the vendor has the right of ownership of the vehicle registration documents.
2. In the case of default of payment on the part of the buyer, the vendor is entitled to withdraw from the purchase agreement. If the vendor is also entitled to claim indemnity in lieu of fulfilment and retakes possession of the object of purchase, then vendor and buyer agree that the vendor shall reimburse the normal resale value of the object of purchase at the time when the object is returned. At the request of the buyer, who is entitled to make such a request only immediately following return of the object of purchase, the buyer may select a publicly appointed and certified vehicle expert, e. g. from Deutsche Automobil Treuhand GmbH (DAT), in order to determine the normal resale value. The buyer shall bear all the costs in connection with the return and sale of the object of purchase. Unless proved otherwise, the additional costs for resale shall be equal to 5 % of the normal resale value. The final amount may vary, subject to the vendor providing proof of higher costs, or the buyer providing proof of lower costs.

VIII: Material

1. With regard to material defects, in the case of new vehicles or new parts (excluding kits), in accordance with the provisions in law the buyer's warranty rights expire after two years following delivery of the object of purchase (exception: Item 7). In deviation from the above, in the case of new vehicles being used for rentals, and in the case of kits or export vehicles, warranty rights expire after one year if the buyer is a legal entity in the public sector, or represents a public sector special fund, or is a business person, who was acting in a commercial capacity or in his capacity as a self-employed person when he concluded the agreement.
In the case of used vehicles or used parts, the buyer's warranty rights in respect of material defects expire after one year following delivery of the object of purchase to the customer. In the case of malicious non-disclosure of the existence of defects, or agreement to grant a guarantee for the condition of the objects, all other rights remain unaffected.
2. With regard to the rectification of defects, the following shall apply:
 - a) The buyer has the right to demand rectification of defects by either the vendor or by any other recognised service centre appointed by the manufacturer/importer to repair or carry out maintenance of the object of purchase; in the latter case the buyer is obliged to make this circumstance known to the vendor. In the case of the buyer informing the vendor verbally of claims, the vendor shall give written confirmation to the buyer that he has received appropriate notification.
 - b) If the object of purchase is out of working order due to a material defect, the buyer may, subject to agreement by the vendor, seek help from a certified vehicle service centre capable of providing assistance and closest to the location of the object of purchase, on condition that the object of purchase which is out of working order is at a location over 100 km away from the vendor's facilities.
 - c) Parts which are removed and replaced shall become the property of the vendor.
 - d) The buyer shall be entitled to claim warranty rights for replacement parts fitted for the purpose of rectifying material defects up until expiry of those warranty rights arising from the purchase agreement which apply to the object of purchase.
3. Changes of ownership shall not affect the right to demand rectification of defects.
4. The vendor ensures that the object of purchase has been manufactured in accordance with recognised technical guidelines based on the technologies employed in limited series manufacturing, and not in mass production.
5. If the buyer does not observe the manufacturer's operating and maintenance instructions, or uses replacement parts or materials/fluids/lubricants which do not conform to the original specifications, he shall forfeit all warranty rights.
6. In the case of excessive and improper use of the object of purchase, i. e. use in motor sporting events, or for example excessive off-road use etc., the buyer shall also forfeit all warranty rights.
7. In the case of reconditioned engines, and reconditioned or used gearboxes, even if fitted to new vehicles, any warranty rights applying to material defects shall always expire after a period of 12 months, regardless of whether the buyer is a private customer or a business person.
8. Acceptance of a job order to carry out repairs is not in itself tantamount to accepting the customer's demand for recognition of warranty rights.
9. Rules of maintenance:

a) General notes and instructions:

All fibreglass parts are laminated by hand, therefore minor irregularities in shape and deviations in colour must necessarily be tolerated by the customer. Uneven tyre wear is inherently caused by the nature of the vehicle's constructional design. Trike and motorcycle riders should always wear suitable protective gear (full-face helmet, leathers, leather boots, leather gloves).

b) Maintenance intervals:

The following vehicle maintenance and servicing intervals should be observed:

- aa) after 500 km, or at the latest 4 weeks after purchase of the vehicle
- bb) after 5,000 km, or at the latest 3 months after purchase of the vehicle
- cc) after 10,000 km, or at the latest 6 months after purchase of the vehicle
- dd) and annually for every subsequent 5,000 km

c) Operating instructions:

Before each journey you must:

- aa) check the oil level
- bb) check the tyre pressures
- cc) check the petrol tank for sufficient fuel
- dd) check for play in the steering head bearings (the fork may only be dismantled by the manufacturer)
- ee) check the brake fluid level
- ff) check that all lights are in working order
- gg) check that all external vehicle parts are secure.

IX: Liability

1. If the vendor is legally required to pay compensation for damage resulting from ordinary negligence, and taking into consideration these terms and conditions, the extent of his liability shall be limited as follows:
The vendor shall only be liable if he has neglected important obligations arising from the purchase agreement, and shall only be liable to compensate for damage of a typical nature and of a kind which is foreseeable at the time of the purchase agreement was concluded. This limitation does not apply in the case of bodily harm and damage to life and health. Insofar as the damage is covered by an insurance taken out by the buyer (excepting endowment insurance), the vendor shall be liable only for subsequent disadvantages experienced by the buyer, e. g. higher insurance premiums, or lost interest until such time as a settlement has been effected by the insurance company: The vendor shall not be liable for any damage resulting from effects to the object of purchase arising out of ordinary negligence.
2. Regardless of whether the vendor is at fault or not, in the case of malicious non-disclosure of the existence of defects, as arising due to acceptance of a guarantee or a purchase risk and in accordance with product liability law, any liability on the part of the vendor shall remain unaffected.
3. With regard to the question of liability arising out of delayed delivery, Section V shall apply.
4. Legal representatives, persons carrying out obligations for the vendor, and the vendor's business associates shall under no circumstances be made personally liable for damage as a result of ordinary negligence on their part, respectively.

X: Vehicle expert arbitration proceedings (applies only to used vehicles)

1. If the motor vehicle company bears the membership insignia of the guild of certified motor vehicle experts "Meisterbetrieb der Kfz-Innung", in the case of any disputes concerning the purchase agreement – except for disagreement over the purchase price – the parties may call upon the arbitrator appointed at the vendor's place of business to mediate in affairs concerning motor vehicles or concerning the trading of used vehicles. The application calling upon the arbitrator to mediate must be made in writing and must be filed immediately as soon as the point at issue becomes known, or at the latest, prior to 13 months after delivery of the object of purchase.
2. The decision of the arbitrator shall not prevent the parties from referring the matter to a court of law.
3. In the event that the arbitrator is called upon to mediate, the statutory period of limitation is suspended for the duration of the arbitration proceedings.
4. The arbitration proceedings are governed by the respective rules and regulations and codes of procedure, which may be presented to the disputing parties at their request.
5. It is not possible to call upon the arbitrator to mediate if the matter has already been referred to a court of law. If the parties refer the matter to a court of law while arbitration is ongoing, the arbitrator will terminate his proceedings.
6. The instigator of the arbitration proceedings is not required to pay the arbitrator any fees.

XI: Place of fulfilment, place of jurisdiction and applicable law

1. The place of fulfilment in respect of delivery of the object of purchase is the place of business of the vendor.
2. The place of business of the vendor shall be the sole place of jurisdiction in connection with all current and future claims arising from business dealings with business persons, including claims in connection with bills of exchange or cheques.
3. The same place of jurisdiction applies if no general place of jurisdiction in Germany applies in the case of the buyer, or if his place of abode or the place where he is ordinarily resident ceases to be Germany after conclusion of the purchase agreement, or if his place of abode or his ordinary place of residence at the time of commencement of legal proceedings is not known. In the case of the vendor filing claims against the buyer, the place of jurisdiction is the place of abode of the buyer.
4. The UN Convention on the International Sale of Goods dated 11 April 1980 does not apply here.

7.0 SERVICE BOOKLET

Warranty*
2 years
 *except vehicle rentals:
1 year

Detachable stub for manufacturer
(to be sent to BOOM TRIKES at the
latest 2 weeks after the service date)

1,000 km service	
Or at the latest 4 months after vehicle purchase. Dealer's stamp:	
Name:	Frame number:
Km:	Date:

----- ✂

1,000 km service	
Or at the latest 4 months after vehicle purchase. Dealer's stamp:	
Name:	Frame number:
Km:	Date:

10,000 km service	
Or at the latest 12 months after vehicle purchase. Dealer's stamp:	
Name:	Frame number:
Km:	Date:

----- ✂

10,000 km service	
Or at the latest 12 months after vehicle purchase. Dealer's stamp:	
Name:	Frame number:
Km:	Date:

20,000 km service	
Or at the latest 24 months after vehicle purchase. Dealer's stamp:	
Name:	Frame number:
Km:	Date:

----- ✂

20,000 km service	
Or at the latest 24 months after vehicle purchase. Dealer's stamp:	
Name:	Frame number:
Km:	Date:

30,000 km service	
Dealer's stamp:	
Name:	Frame number:
Km:	Date:

----- ✂

30,000 km service	
Dealer's stamp:	
Name:	Frame number:
Km:	Date:

----- ✂

✂ -----

Name	
Street	
Post code/ city	
Tel.	
1 st registration	
Purchased on	
at	

✂ -----

Name	
Street	
Post code/ city	
Tel.	
1 st registration	
Purchased on	
at	

✂ -----

Name	
Street	
Post code/ city	
Tel.	
1 st registration	
Purchased on	
at	

✂ -----

Name	
Street	
Post code/ city	
Tel.	
1 st registration	
Purchased on	
at	

Name	
Street	
Post code/ city	
Tel.	
1 st registration	
Purchased on	
at	

Name	
Street	
Post code/ city	
Tel.	
1 st registration	
Purchased on	
at	

Name	
Street	
Post code/ city	
Tel.	
1 st registration	
Purchased on	
at	

Name	
Street	
Post code/ city	
Tel.	
1 st registration	
Purchased on	
at	

40,000 km service	
Dealer's stamp:	
Name:	Frame number:
Km:	Date:

----- ✂

40,000 km service	
Dealer's stamp:	
Name:	Frame number:
Km:	Date:

50,000 km service	
Dealer's stamp:	
Name:	Frame number:
Km:	Date:

----- ✂

50,000 km service	
Dealer's stamp:	
Name:	Frame number:
Km:	Date:

60,000 km service	
Dealer's stamp:	
Name:	Frame number:
Km:	Date:

60,000 km service	
Dealer's stamp:	
Name:	Frame number:
Km:	Date:

70,000 km service	
Dealer's stamp:	
Name:	Frame number:
Km:	Date:

----- ✂

70,000 km service	
Dealer's stamp:	
Name:	Frame number:
Km:	Date:

----- ✂

✂ -----

Name	
Street	
Post code/ city	
Tel.	
1 st registration	
Purchased on	
at	

Name	
Street	
Post code/ city	
Tel.	
1 st registration	
Purchased on	
at	

✂ -----

Name	
Street	
Post code/ city	
Tel.	
1 st registration	
Purchased on	
at	

Name	
Street	
Post code/ city	
Tel.	
1 st registration	
Purchased on	
at	

✂ -----

Name	
Street	
Post code/ city	
Tel.	
1 st registration	
Purchased on	
at	

Name	
Street	
Post code/ city	
Tel.	
1 st registration	
Purchased on	
at	

✂ -----

Name	
Street	
Post code/ city	
Tel.	
1 st registration	
Purchased on	
at	

Name	
Street	
Post code/ city	
Tel.	
1 st registration	
Purchased on	
at	

80,000 km service	
Dealer's stamp:	
Name:	Frame number:
Km:	Date:

----- ✂

80,000 km service	
Dealer's stamp:	
Name:	Frame number:
Km:	Date:

----- ✂

90,000 km service	
Dealer's stamp:	
Name:	Frame number:
Km:	Date:

90,000 km service	
Dealer's stamp:	
Name:	Frame number:
Km:	Date:

100,000 km service	
Dealer's stamp:	
Name:	Frame number:
Km:	Date:

100,000 km service	
Dealer's stamp:	
Name:	Frame number:
Km:	Date:

110,000 km service	
Dealer's stamp:	
Name:	Frame number:
Km:	Date:

110,000 km service	
Dealer's stamp:	
Name:	Frame number:
Km:	Date:

----- ✂

✂ -----

Name	
Street	
Post code/ city	
Tel.	
1 st registration	
Purchased on	
at	

✂ -----

Name	
Street	
Post code/ city	
Tel.	
1 st registration	
Purchased on	
at	

✂ -----

Name	
Street	
Post code/ city	
Tel.	
1 st registration	
Purchased on	
at	

✂ -----

Name	
Street	
Post code/ city	
Tel.	
1 st registration	
Purchased on	
at	

Name	
Street	
Post code/ city	
Tel.	
1 st registration	
Purchased on	
at	

Name	
Street	
Post code/ city	
Tel.	
1 st registration	
Purchased on	
at	

Name	
Street	
Post code/ city	
Tel.	
1 st registration	
Purchased on	
at	

Name	
Street	
Post code/ city	
Tel.	
1 st registration	
Purchased on	
at	

8.0 MAINTENANCE AND SERVICE INTERVALS

Maintenance should only be carried out by a specialist car dealer, a specialist motorcycle dealer (Piaggio or Aprilia) or by an authorised BOOM dealer.

The following service instructions assume that the trike is used exclusively as the manufacturer originally intended. If you ride it at consistently high engine speeds, or in unusually wet or dusty conditions, or rent the vehicle out, then it will require attention at shorter intervals than those specified in the service booklet.

Your authorised BOOM TRIKES dealer will be able to advise you on an appropriate service itinerary for your trike.

Regular servicing will ensure that your trike maintains its value and roadworthiness. A worldwide network of over 100 BOOM Trikes dealers and several thousand car and motorcycle dealers is at your disposal to ensure that your trike can always be properly maintained.

Check ■ Replace ●	x 1000 km months	1	10	20	30	40	50	60	70	80	90	100	110	120
		4	12	24										
Engine oil	<i>Check oil level / top up</i>													
		EVERY 3000 km												
Engine oil	<i>Change oil</i>	●	●	●	●	●	●	●	●	●	●	●	●	●
Gearbox oil (Differential gearbox)	<i>Check oil level / change oil</i>	■	■	■	■	■	■	●	■	■	■	■	■	
Spark plug/ plug gap	<i>Check / replace</i>		■	●	■	●	■	●	■	●	■	●	■	●
Air filter	<i>Replace / clean</i>		■	●	●	●	■	●	■	●	■	●	■	●
Oil filter	<i>Replace</i>		●		●		●		●		●		●	
Petrol filter	<i>Check / replace</i>					■				●				■
Valve clearances 0.15 mm (all valves)	<i>Check</i>	■			■			■			■			■
Petrol mixture	<i>Check / adjust</i>	■		■		■		■		■		■		■
Seals, leaks from petrol & brake lines, FI system	<i>Visual check</i>	■		■		■		■		■		■		■
Oil sump breather	<i>Visual check</i>	■	■	■	■	■	■	■	■	■	■	■	■	■
Variators	<i>Replace</i>			●		●		●		●		●		●
Curved track shoes	<i>Check / replace</i>			■		●		■		●		■		●
Bush, driven belt pulley	<i>Check / grease</i>					■				■				■
Drive belt	<i>Replace</i>		●	●	●	●	●	●	●	●	●	●	●	●
Coolant level	<i>Check</i>		■	■	■	■	■	■	■	■	■	■	■	■
Coolant	<i>Replace</i>													
		EVERY 2 YEARS												
Radiator	<i>Clean exterior / check</i>	■	■	■	■	■	■	■	■	■	■	■	■	■
Steering head bearings	<i>Check / grease</i>	■	■	■	■	■	■	■	■	■	■	■	■	■
Oil pinion	<i>Replace</i>	■		●		●		●		●		●		●
Brake pads	<i>Check condition and wear</i>													
		EVERY 3000 km												
Brake fluid level	<i>Check</i>	■	■	■	■	■	■	■	■	■	■	■	■	■
Brake fluid	<i>Replace</i>													
		EVERY 2 YEARS												
Torque settings	<i>Check</i>	■		■		■		■		■		■		■
Suspension, front and rear, springs, dampers	<i>Check</i>	■		■		■		■		■		■		■
Fork oil (only telescopic fork)	<i>Check / replace</i>	■	■	■	■	■	■	●	■	■	■	■	■	●
Electr. system, battery	<i>Check</i>	■	■	■	■	■	■	■	■	■	■	■	■	■
Headlamps	<i>Check / adjust</i>			■		■		■		■		■		■
Tyres	<i>Check pressures & tread wear</i>		■	■	■	■	■	■	■	■	■	■	■	■
Vehicle and brake test	<i>Test ride</i>	■	■	■	■	■	■	■	■	■	■	■	■	■
Throttle body	<i>Clean / adjust</i>				■			■			■			■
Air filter CVT	<i>Clean</i>			■		■		■		■		■		■

(For a list of recommended lubricants see page 1)

TECHNICAL SPECIFICATIONS, LIQUID-COOLED 4-STROKE, 4-VALVE, 500 C.C. ENGINE

ENGINE

Type:	Single cylinder 4-stroke
Bore:	92 mm
Stroke:	69 mm
Cubic capacity:	460 c.c.
Compression ratio:	10.5 : 1
Valve train:	Single overhead camshaft, chain-driven from the alternator side, integrated camshaft sensor (tone wheel), 4 valves and automatic valve lifter for starting
Valve clearances:	Inlet : 0.15 mm Exhaust: 0.15 mm
Valve adjustment	Tappet adjusters on rocker arms
Idling speed:	1450 ± 50 rpm
CO2 value (%):	1.2 – max 1.5
Starter:	Electric starter motor
Lubrication:	Trochoidal oil pump in crankcase, oil filter, bypass regulates oil pressure
Oil pressure:	4 bar
Lowest permissible oil pressure (at 100° C)	0.8 bar
Carburation:	Electronic fuel injection, electrical fuel pump, Ø38 mm throttle, individual fuel injectors
Max. power (at crankshaft)	29 kW (40 bhp) at 7,250 rpm
Max. torque / rpm	40 Nm at 5,500 rpm
Cooling system	Liquid cooled engine, crankshaft driven water pump, 3-way thermostat and fan
Power train	CVT automatic gearbox with conical pulleys, belt drive, automatic clutch, reduction gear unit, fan in drive housing
Ignition	Inductive ignition system integrated into fuel injection system, variable ignition timing and separate ignition coil
Ignition timing	Variable, FI-controlled
Spark plug	CHAMPION RG 6 YC, NGK CR 7 EKB
Engine oil	SAE 5W/40 oil, must exceed API SY
Oil capacity:	~ 1.7 ltrs.
Cooling system, capacity:	~ 2.0 ltrs.

Checking for top dead centre (TDC)

- Use a Torx key to open the inspection cover on the alternator cover.
- Remove the drive belt cover and its damping material.
- Remove the rocker cover on the cylinder head.
- Rotate the crankshaft at the pulley until the marking at the magnet holder points to the marking on the alternator cover (TDC).
- Make sure that the marking at the camshaft sensor points to the marking on the cylinder head. If it points in the opposite direction, then rotate the crankshaft through 360° again.

Checking and adjusting the valve clearances

- Only check and adjust the valve clearances when the engine is cold.
- Before checking the valve clearances ensure that you have obtained top dead centre as described in the section above.
- Use a feeler gauge and insert it in the gap between the valve adjuster and the valve. If one or more gaps deviate from the clearances specified below, then adjust the inlet and exhaust sides of the cylinder head accordingly. Loosen the locknut and turn the adjuster as depicted in the diagram.
- Inlet valve: 0.15 mm (cold)
- Exhaust valve: 0.15 mm (cold)

Checking engine compression

- On a cold engine, remove the spark plug cap.
- Unscrew the spark plug.
- Using a 10 mm adapter, screw a compression gauge into the plug hole and tighten down to the correct torque.
- Press the starter, and with the twistgrip open at full throttle rotate the crankshaft until the compression gauge readings no longer fluctuate. Check if the reading equals the prescribed value of 8 ± 1 bar. If so, then remove the compression gauge and screw the spark plug back in.
- If the readings are lower, then check the engine speed when you press the starter. If the engine speed is less than 450 rpm, then check the electric starter. If the engine speed is equal to the above value or slightly higher, i.e. is correct, then check for correct valve timing.
- Check if the correct barrel gasket has been fitted.
- Check for worn piston rings, sticking valves etc.

Torque setting:

Compression gauge adapter: 10 Nm

Recommended torque settings

Standard torque settings

All values in Nm			
Thread diameter of bolt	Bolted to plastic surfaces with a metal washer	Bolted to bronze, copper, aluminium surfaces and various alloys	Bolted to iron and steel surfaces
M4	2	2	3
M5	4	4	6
M6	6.5	6.5	10.5
M7		10.5	17
M8		16	26
M9			52
M10			100
M14			145

Vehicle component	Quantity	Torque setting (Nm)
Motor		
Clutch securing nut	1	65 – 75
Bolts securing shaft bearing, driven belt pulley	4	23 – 26
Belt tensioner roller, securing bolt	1	17 – 20
Drive pulley, nut	1	160 – 175
Alternator, nut (°)	1	115 – 125
Driven pulley, nut	1	92 – 100
Bolts joining crankcase halves	14	11 – 13
Rocker cover bolts	4	11 – 13
Cylinder head nuts (°) (■) (*)	4	38 – 42
Cylinder head studs	4	44 – 46
Camshaft cage bolt (■)	1	30 – 35
Camshaft plate securing bolt (■)	3	4 – 6
Tappet adjuster nut	4	6 – 8
Water pump wheel	1	4 – 5
Starter motor bolts	2	11 – 13
Spark plug	1	12 – 14
Oil drain plug, gearbox oil	1	15 – 17
Differential gearbox, cover bolts	6	24 – 27
Transmission cover, bolts	7	11 – 13
Oil pump, bolts	2	8 – 10
Oil drain plug, engine oil	1	24 – 30
Water pump, cover bolts	6	3 – 4
Oil pump to crankcase, securing bolts	2	5 – 6
Stator bolts	3	8 – 10
Starter clutch to flywheel, bolts (■)	6	13 – 15
Alternator cover bolts	14	11 – 13
Manifold to cylinder head, bolts	3	11 – 13
Choke unit to manifold, bolt	3	11 – 13
Camchain tensioner runner, bolt (■)	1	10 – 14
Camchain tensioner, bolt	1	5 – 6
Camchain tensioner mounting, bolt	2	11 – 13
Balance shaft, nut (■)	4	25 – 29
Silencer to mounting, bolts	2	20 – 25
Exhaust downpipe to cylinder head, nuts	2	27 – 23
Rear brake calliper to engine, nut	2	20 – 25
Timing inspection cover	1	3.5 – 4.5
Cover, water return pipe, bolts	2	3 – 4
Jiggle pin	1	5 – 7
Dipstick	1	1.5 – 2.5
Oil filter	1	12 – 16
Oil breather pipe	1	3 – 4
Oil pressure sensor	1	12 - 14
Wiring mountings	2	3 – 4
Mountings on cylinder head / barrel / crankcase	5	10 – 12
Camshaft sensor / tone wheel	2	3 – 4
Water temperature sensor	1	10 – 12
Counterweight, valve lifter	1	7 – 8.5
Gear, layshaft to crankshaft (■)	5	10 – 12
Thermostat cover	2	1.5 – 2
Plate, layshaft to starter gear	3	3 – 4
Fuel injector mounting (■)	1	3 – 4
Inspection plug, cylinder head oilways	1	5 - 7

(°) Apply grease before fitting.

(^) Apply LOCTITE 510 liquid gasket

(■) Apply LOCTITE 242 thread sealant

(*) 1st tightening sequence: Cross-tighten at 20 Nm, then cross-tighten at 38 – 42 Nm. Loosen crosswise.

(*) 2nd tightening sequence: Cross-tighten at 20 Nm, then cross-tighten at 38 – 42 Nm. NB: Grease threads.

Body and crankshaft

Components	Torque reference values (Nm)
Locking plate gear	3 ÷ 4
Connecting screw body (M6)	11 ÷ 13
Connecting screw body (M8)	25 ÷ 28

9.0 PRE-DELIVERY VEHICLE CHECKS

Vehicle checks

- Paintwork
- Panel gaps, bodywork parts
- Vehicle damage
- All surfaces clean

Torque settings

- Torque settings in safety-relevant areas
- Securing bolts

Electrical system

- Ignition switch
- Headlamp angle in accordance with legal requirements
- Tail light, parking light, brake light
- Indicators and indicator warning light
- Instrument panel lights
- Instruments: petrol gauge and water temperature gauge
- Warning lights
- Horn
- Hazard warning lights
- Engine cutout function actuated by handbrake

Fluids and lubricants

- Petrol in fuel tank
- Brake fluid level
- Differential gearbox, oil level
- Engine oil level
- Coolant level

Test ride

- Cold start
- All instruments in working order
- Throttle response
- Vehicle stability when accelerating and braking
- Braking performance, front and rear brakes
- Damping, front and rear
- Excessive noise
- Check correct chain tension and automatic chain lubrication

Vehicle checks after test ride

- Warm start
- Even idling speed (turn handlebars from lock to lock)
- Free and even handlebar movements
- Steering head bearings for play. No knocking should be felt.

Vehicle function checks

- Braking Brake lever travel
- Clutch Function checks
- Engine Throttle cable adjustment
- Other:
 - Check vehicle documents
 - Check frame and engine numbers
 - Check toolkit
 - Fit number plate
 - Check locks
 - Check tyre pressures
 - Fit rear-view mirrors and any optional extras